

USER'S MANUAL

LABORATORY CENTRIFUGE CENTRIC 260 CENTRIC 260 R



| <u>Edition</u> | <u>Month</u> | <u>Year</u> |
|----------------|--------------|-------------|
| 3. | May | 2024 |

ID 413304

DOMEL®

Domel, d.o.o.
Otoki 21, 4228 Železniki, Slovenia
Business Unit Laboratory Systems
Na Plavžu 79, 4228 Železniki, Slovenia
Tel.: +386 (0)4 5117 500
Internet: <https://www.domel.com>

PREFACE

Dear customer,

Congratulations for purchasing our centrifuge CENTRIC 260 / R. You have selected a reliable device which combines many advantages.

A wide selection of programming options and electronic control allow trouble-free operation. The brushless motor provides quiet, maintenance-free operation without any carbon dust pollution.

Your device is equipped with user-friendly functions, which makes the operation and settings easier for you. Built-in safety functions prevent incorrect usage and they control the complete operation of the centrifuge.

The centrifuge has the functionality to save programs. You can save up to 100 different data sets in the memory. The centrifuge always keeps the last run program in its memory for an unlimited amount of time, allowing the program to be restarted at any time - even if the centrifuge was turned off in-between. All operation parameters can be seen at a glance on the displays.

The settings are executed via a knob and the keys on the control panel.

The centrifuge and its interior are easy to clean.

We thank you for your confidence and we hope you enjoy your new centrifuge.

Domel, d.o.o.
Business Unit Laboratory Systems

Na Plavžu 79,
4228 Železniki, Slovenia

Tel.: +386 (0)4 5117 500
Internet: <https://www.domel.com>

TABLE OF CONTENTS

| | Page |
|--|-----------|
| PREFACE | 2 |
| TABLE OF CONTENTS | 3 |
| 1. SAFETY INFORMATION | 4 |
| 1.1 WARNING SYMBOLS..... | 4 |
| 1.2 SAFETY INSTRUCTIONS..... | 4 |
| 2. INTRODUCTION | 6 |
| 2.1 INTENDED USE | 6 |
| 2.2 BASIC EQUIPMENT | 6 |
| 2.3 UNPACKING AND LIFTING OF THE DEVICE..... | 6 |
| 2.4 INSTALLING THE CENTRIFUGE | 6 |
| 2.5 OVERALL VIEW | 7 |
| 3. OPERATION | 9 |
| 3.1 CONTROL PANEL..... | 9 |
| 3.2 KNOB AND KEY FUNCTIONS..... | 10 |
| 3.3 TURNING ON THE CENTRIFUGE | 12 |
| 3.4 OPENING AND CLOSING OF THE LID..... | 12 |
| 3.5 ROTOR MOUNTING AND DISMOUNTING | 12 |
| 3.6 ROTOR LOADING | 13 |
| 3.7 COOLING SETTING (Only for CENTRIC 260 R) | 14 |
| 3.8 SETTING THE ROTATIONAL SPEED AND CENTRIFUGAL FORCE | 14 |
| 3.9 SETTING RUN TIME, ACCELERATION AND BRAKING LEVEL..... | 15 |
| 3.10 PROGRAM SETTING | 16 |
| 3.11 STARTING AND STOPPING THE CENTRIFUGE | 17 |
| 3.12 ROTOR RECOGNITION | 17 |
| 3.13 DISPLAY OF THE SET VALUES DURING THE RUN..... | 17 |
| 3.14 FAST SPIN | 17 |
| 3.15 FAST COOL FUNCTION (Only for CENTRIC 260 R)..... | 18 |
| 3.16 RESET OF LID LATCH..... | 18 |
| 3.17 AUXILIARY LID RELEASE..... | 18 |
| 3.18 AUTOMATIC BRAKING AFTER POWER RESTORATION..... | 18 |
| 3.19 TEMPERATURE CORRECTION (Only for CENTRIC 260 R)..... | 19 |
| 4. MAINTENANCE AND CLEANING OF THE CENTRIFUGE | 19 |
| 4.1 REGULAR SERVICE | 19 |
| 4.2 CLEANING THE CENTRIFUGE..... | 19 |
| 4.3 CLEANING THE ROTOR..... | 19 |
| 4.4 ROTOR STERILIZATION..... | 19 |
| 5. TROUBLESHOOTING | 20 |
| 5.1 ERROR MESSAGES | 20 |
| 5.2 EXIT FROM ERROR DISPLAY | 21 |
| 5.3 USER'S PARAMETERS..... | 22 |
| 5.4 REPLACING THE CENTRIFUGE FUSES..... | 23 |
| 6. TECHNICAL DATA | 23 |
| 7. APPENDIX | 25 |
| 7.1 CALCULATION OF CENTRIFUGAL FORCE | 25 |
| 7.2 CALCULATION OF MAXIMUM PERMITTED ROTOR SPEED | 25 |
| 7.3 EQUIPMENT DECONTAMINATION | 25 |
| 7.4 TRANSPORT AND STORAGE | 26 |
| 7.5 EQUIPMENT DISPOSAL | 26 |
| EU DECLARATION OF CONFORMITY | 27 |

1. SAFETY INFORMATION

Before using the machine, make sure to read and understand this manual thoroughly. Keep the manual close to the machine, easily accessible to all the users.

Improper operation can cause injury to persons or damage to the equipment.

1.1 WARNING SYMBOLS

The following are the warning symbols that are used in this manual and on the machine.

| | |
|---|---|
|  | This symbol indicates a potential risk and alerts you to proceed with caution. Documentation must be consulted in all cases where this symbol is marked, in order to find out the nature of the potential hazards and any actions which have to be taken to avoid them. |
|---|---|

| | |
|---|--|
|  | This symbol indicates potential biological risks and alerts you to proceed with caution. |
|---|--|

1.2 SAFETY INSTRUCTIONS

In the interest of your own personal safety, always observe the following safety instructions:

- Do not use rotors and buckets, which show clear signs of corrosion or mechanical defects. Please check the accessories at regular intervals.
- Always load the rotor with the same test tubes on all positions or symmetrically with the pairs of the same test tubes. To prevent negative consequences of unbalanced rotor, like damaged bearings and motor axle, or inadequate results of centrifugation, equal or equally loaded test tubes must be symmetrically arranged regarding to the rotation axis.
- Please use only the original accessories for centrifugation.
- Do not move or knock the centrifuge during operation!
- Repairs must only be performed by an authorized service technician.
- The centrifuge may only be used for specified applications. It may not be used in a hazardous or potentially flammable environment and for centrifugation of explosive or highly reactive substances.
- When handling toxic, aggressive or radioactive materials, observe national regulations or regulations defined by World Health Organization.
- Fluids or materials used for cleaning and disinfecting should be disposed of in accordance with approved laboratory regulations.
- If any liquids are spilled in the rotor chamber, on the rotor or accessories, the surfaces must be cleaned immediately. You can use a damp cloth and mild soap solution. This is particularly important for the cleaning of the bores of the fixed-angle rotors.
- Density of the liquid must not be exceeded 1.2 g/ml at maximum rotational speed.

- During longer spin times, test tubes may heat up. Observe the requirements and regulations specified by test tube manufacturer.
- The use of organic solvents and reagents may have adverse effect on the stability of plastic test tubes.
- Rotors are high-grade components which are subjected to extreme mechanical strain. Aluminium rotors are protected against corrosion.
- Please ensure that the rotors are protected from mechanical damage. Even slight scratches and cracks can cause severe inner damage to the rotor material.
- Please clean your rotors regularly using a neutral cleaning liquid (e.g. Extran...). This will protect the rotors and maintain their service life.
- If the unit is used in a manner not specified by the manufacturer the degree of protection provided by the unit may be impaired.
- Only trained operator is allowed to use the centrifuge.
- The operator shall wear gloves as protective equipment.
- During cleaning, it is necessary to use protective gloves or other safeguards.
- Bioseals are not to be relied on as the only means of safeguarding workers and the environment when handling pathogenic micro-organisms. Bioseals and related components are intended to be part of bio-containment systems as specified in international and national bio-safety guidelines instructions for use of bioseals and other bio-containment components.
- You should use caution when the materials to be used with a laboratory centrifuge are known to be toxic, radioactive, or contaminated with pathogenic micro-organisms.
- If hazardous material is spilt, it is your responsibility to carry out appropriate decontamination.
- Before using any cleaning or decontamination methods except those recommended by the manufacturer, you should check with the manufacturer that the proposed method will not damage the equipment.
- Cleaning and decontamination may be necessary as a safeguard before laboratory centrifuges, rotors, and any accessories are maintained, repaired, or transferred.
- Inspection of the protective casing, routine maintenance and the replacement of bioseals and other bio-containment components should be regularly performed by authorised service.
- The centrifuge may only be used in laboratories with basic electromagnetic environment.

2. INTRODUCTION

2.1 INTENDED USE

Centrifuge CENTRIC 260 / R (mark R means refrigerating model) is a laboratory centrifuge intended to be used in laboratories for separating the substances with different specific densities by centrifugal force.

The maximum rotational speed of 18000 RPM gives the centrifugal force of 31150 x g.



Before starting the centrifuge CENTRIC 260 / R for the first time, please read this user's manual and observe the safety regulations.

2.2 BASIC EQUIPMENT

The following is enclosed with the centrifuge:

- 1 User's manual
- 1 Hexagonal rotor key (magnetic key holder on the back side of the centrifuge, see page 8)
- 1 Power cord (cross section of the cord shall be minimum 3 x 0.75 mm²)

2.3 UNPACKING AND LIFTING OF THE DEVICE

The weight of the centrifuge is 22.5 kg (50 kg for refrigerating model). To prevent possible injuries, at least two people should lift and carry the centrifuge by holding it at the bottom from opposite sides.

Open the carton box. Take out the accessories and remove the packaging material. Reach with your hands under the centrifuge and lift it from the box together with another person.



When lifting the centrifuge, never hold it by the front or top plastic part of the housing or by the lid, as the appliance may get damaged!

Retain the packaging material for any subsequent transport or storage, which are allowed only in the original packaging.

2.4 INSTALLING THE CENTRIFUGE

The centrifuge should only be operated indoors. Place the centrifuge on a stable, solid, horizontal and clean surface, without vibrations. Make sure that the centrifuge is not exposed to direct sunlight. To ensure sufficient ventilation, there should be enough clearance on all sides of the centrifuge. It must be far enough away from the wall and other devices. According to recommendations of the EN 61010-2-020 standard, a safety clearance of 30 cm should be observed around the centrifuge during operation. No objects or persons should be within this area because there is a possibility of injury in the event of centrifuge failure.

If the centrifuge isn't levelled, imbalances can occur, and the centrifuge can be damaged. Do not place anything under the centrifuge feet to level the centrifuge.

**For CENTRIC 260:**

After installation, it is recommended that you wait for some time, before connecting the centrifuge to the mains power supply. This prevents damage to electronic components due to condensation, which can occur, when you bring the device from a cold environment to a warm environment.

**For CENTRIC 260 R:**

After installation you have to wait for at least four hours, before connecting the centrifuge to the mains power supply. This prevents possible damage to the compressor, which may result from improper transport.

This also prevents damage to electronic components due to condensation, which can occur, when you bring the device from a cold environment to a warm environment.

Before connecting the centrifuge to the mains power supply, check that the mains voltage and frequency correspond to the specifications on the name label of the centrifuge. The mains cable of the centrifuge may only be connected to a properly grounded wall socket.

To disconnect the mains supply from the centrifuge in the event of malfunction, an emergency switch separate from the centrifuge must be available. This switch should be outside the room, where the centrifuge is installed, or next to the entrance to the room.

2.5 OVERALL VIEW

Main parts of the centrifuge are designated on the following pictures.

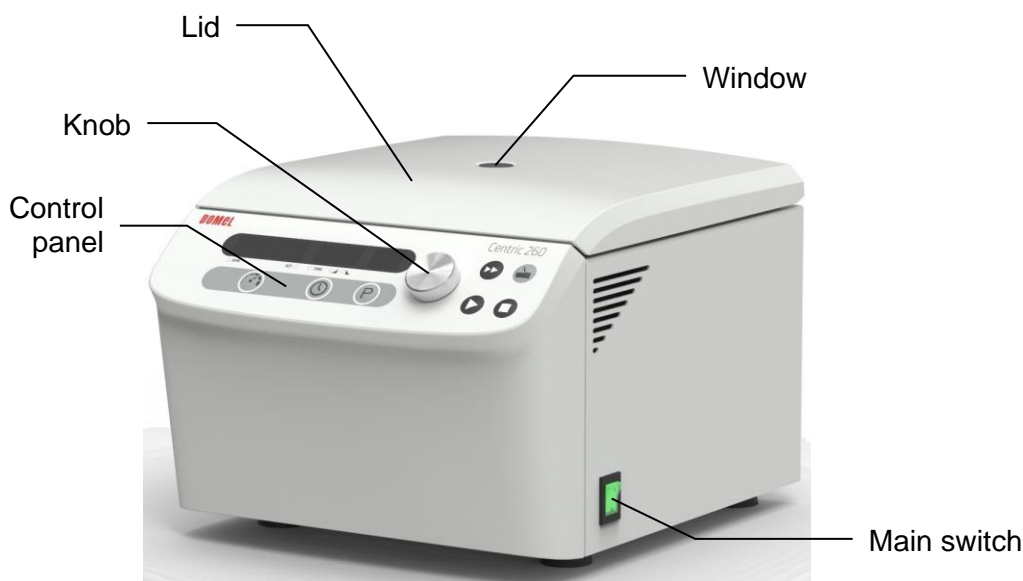
CENTRIC 260:

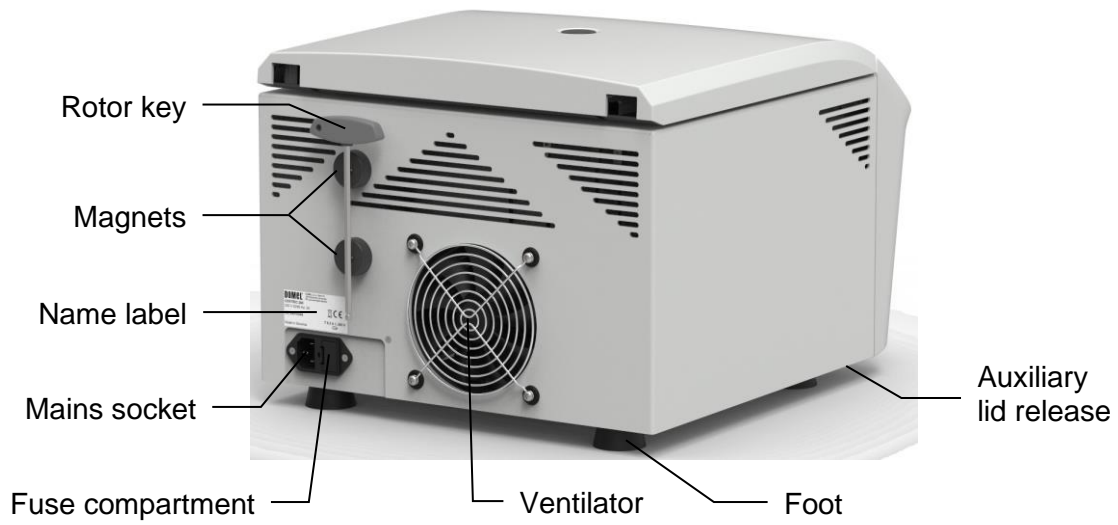

CENTRIC 260 R:

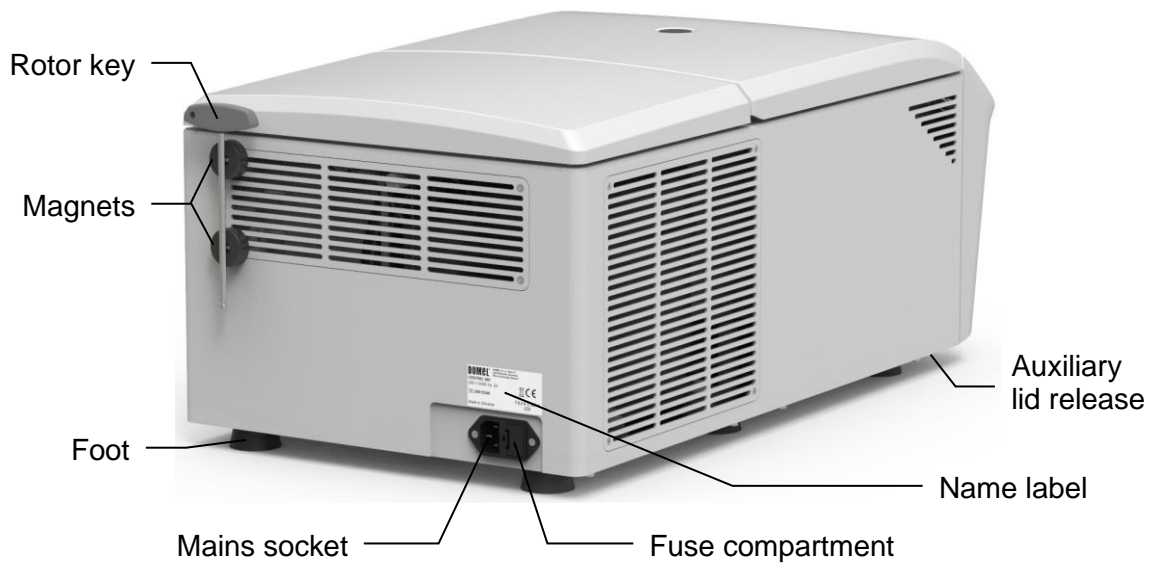
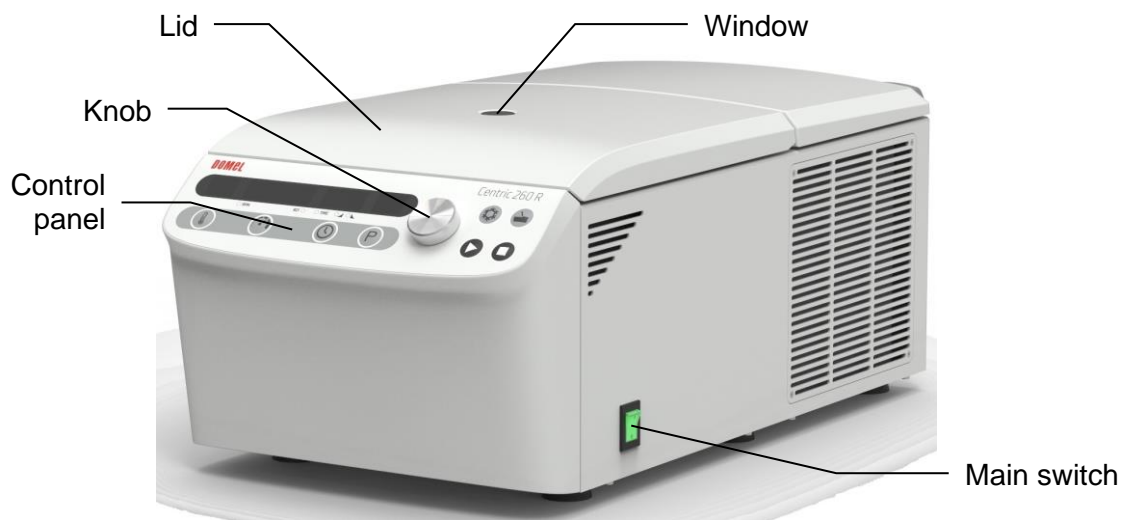

3. OPERATION

Before using the centrifuge for the first time, familiarize yourself with the control panel and the functions of the knob and keys.

3.1 CONTROL PANEL

CENTRIC 260:

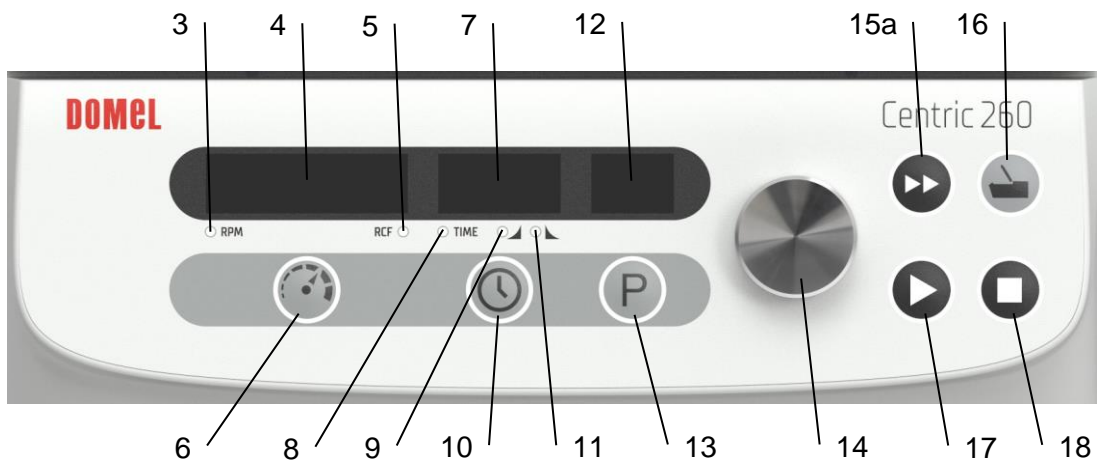

CENTRIC 260 R:

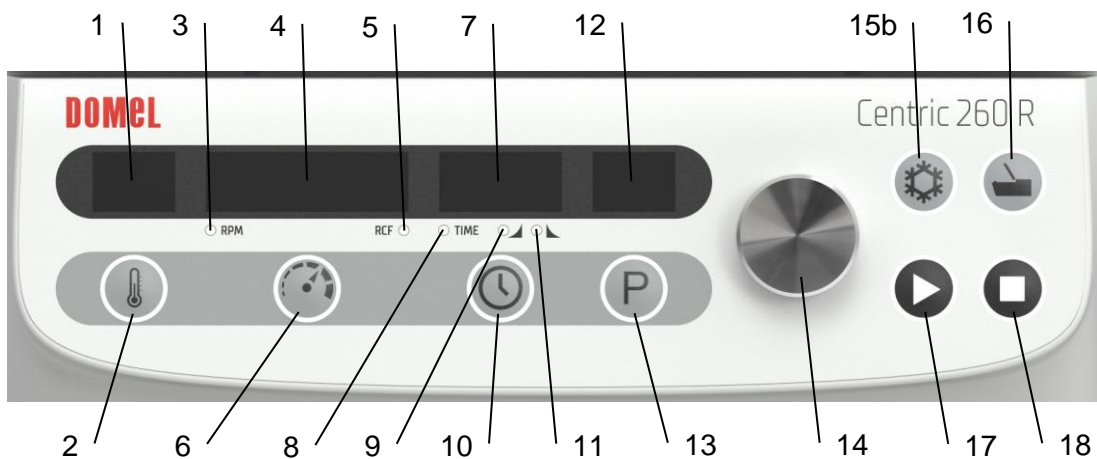









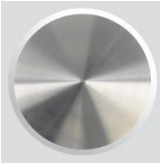

DESCRIPTION:

| | |
|---|---|
| 1 | Temperature display (Only on CENTRIC 260 R) |
| 2 | TEMPERATURE key (Only on CENTRIC 260 R) |
| 3 | Indicator for selection of rotational speed (RPM) |
| 4 | Display for rotational speed (RPM) or centrifugal force (RCF) |
| 5 | Indicator for selection of centrifugal force (RCF) |
| 6 | SPEED key |
| 7 | Display for time (TIME), acceleration level (▲) and braking level (▼) |
| 8 | Indicator for selection of time (TIME) |
| 9 | Indicator for selection of acceleration level (▲) |

| | |
|-----|--|
| 10 | TIME key |
| 11 | Indicator for selection of braking level (▲) |
| 12 | Program display |
| 13 | PROGRAM key |
| 14 | Knob |
| 15a | FAST SPIN key (Only on CENTRIC 260) |
| 15b | FAST COOL key (Only on CENTRIC 260 R) |
| 16 | LID key |
| 17 | START key |
| 18 | STOP key |

3.2 KNOB AND KEY FUNCTIONS

| | |
|--|--|
|  <p>(Knob)</p> | <p>By rotating the knob, you change the values of the parameters on display. By rotating the knob clockwise, the value increases, and by rotating it counter-clockwise, the value decreases. By pressing on the knob, you confirm the new value for the parameter.</p> |
|  <p>(TEMPERATURE)</p> | <p>(Only on CENTRIC 260 R) By pressing this key, you can set the temperature. The key lights up. Set new temperature by rotating the knob and confirm it by pressing on the knob. The key light will then turn off.</p> |
|  <p>(SPEED)</p> | <p>By pressing this key, you can set the rotational speed (RPM) or centrifugal force (RCF). The key lights up. By repeated pressings on this key, you select which parameter will be set. When indicator RPM is lit, you can set the rotational speed, and when indicator RCF is lit, you can set the centrifugal force. Set new values of both parameters by rotating the knob and confirm them by pressing on the knob. The key light will then turn off.</p> |
|  <p>(TIME)</p> | <p>By pressing this key, you can set the time (TIME), acceleration level (▲) and braking level (▲). The key lights up. By repeated pressings on this key, you select which parameter will be set. When indicator TIME is lit, you can set the run time, when indicator ▲ is lit, you can set the acceleration level, and when indicator ▲ is lit, you can set the braking level. Set new values of all parameters by rotating the knob and confirm them by pressing on the knob. The key light will then turn off.</p> |
|  <p>(PROGRAM)</p> | <p>By pressing this key, you can set the programs. The key lights up. Select new program by rotating the knob and confirm it by pressing on the knob. The key light will then turn off. If you want to change the values of parameters of an existing program, set the values of individual parameters as described above, when this key is lit.</p> |

| | |
|--|---|
|  <p>(FAST SPIN)</p> | <p>(Only on CENTRIC 260)</p> <p>By pressing and holding this key, you perform the fast spin. The centrifuge runs for as long as you hold the key pressed. Time of run in seconds is displayed on time display. The acceleration and braking levels are fixed to 9 (the highest), and they can't be changed. When you release the key, the braking procedure of the rotor is activated and the centrifuge stops.</p> |
|  <p>(FAST COOL)</p> | <p>(Only on CENTRIC 260 R)</p> <p>By pressing this key, you turn on the fast cool function. The key lights up. Rotor starts to run automatically with 8000 RPM. Fast cool function cools down the centrifugal chamber to the set temperature. When the temperature is reached, display for rotational speed shows message READY, and the key light will then turn off.</p> |
|  <p>(LID)</p> | <p><u>SHORT PRESS:</u></p> <p>By pressing this key, you open the lid of the centrifuge. When the lid opens, the key light turns off. When closing the lid, press it down with your hands, until it locks up. When the lid is closed, the key lights up.</p> <p>The key light turns off during the run of the centrifuge and thus indicates that you can't open the lid during the run.</p> |
| | <p><u>LONG PRESS:</u></p> <p>By pressing and holding this key, you set the lid latch to initial position. This is needed in case of power failure during the opening of the lid, when lid latch motor stops in undefined position. When power returns, it could happen that you can't open or close the lid. If this happens, press the key for approximately five seconds, until you hear the sound of lid latch motor, then release it. After that, you will be able to open and close the lid normally.</p> |
|  <p>(START)</p> | <p><u>SHORT PRESS:</u></p> <p>By pressing this key, you start the run of the centrifuge. The key lights up and thus indicates that the centrifuge is running.</p> <p>At the end of the set running time or manual stopping of the centrifuge, the braking procedure of the rotor is activated and the centrifuge stops. The next run is possible, when the rotor stops completely.</p> |
| | <p>(Only on CENTRIC 260 R)</p> <p><u>LONG PRESS:</u></p> <p>By pressing and holding this key, you perform the fast spin. The centrifuge runs for as long as you hold the key pressed. Time of run in seconds is displayed on time display. The acceleration and braking levels are fixed to 9 (the highest), and they can't be changed. When you release the key, the braking procedure of the rotor is activated and the centrifuge stops.</p> |
|  <p>(STOP)</p> | <p>By pressing this key, you stop the run of the centrifuge. The key lights up and thus indicates that the centrifuge is stopping. The braking procedure of the rotor is activated and the centrifuge stops. Until the centrifuge stops completely, the START key remains lit, thus indicating that the rotor is still turning.</p> |

3.3 TURNING ON THE CENTRIFUGE

Use the enclosed power cord to connect the centrifuge to the mains power supply.

Turn on the main switch, which is located on the front of the right side of the centrifuge.

All segments (eights) are displayed on all displays at first, and all the keys and indicators light up simultaneously. Then centrifuge model (C-260 or C-260R) and program version (X.XX) are displayed, then lines, and finally the values of operation parameters are displayed.

The values of operation parameters (temperature (only on CENTRIC 260 R), rotational speed, centrifugal force, run time, acceleration and braking level) are automatically set to the last used values.

3.4 OPENING AND CLOSING OF THE LID



By pressing the LID key, you open the lid of the centrifuge. When the lid is open, the key light turns off.

When closing the lid, press it down with your hands, until it locks up. When the lid is closed, the key lights up.

The key light turns off during the run of the centrifuge and thus indicates that you can't open the lid during the run.



Always open the centrifuge lid completely, to prevent it from falling!

When closing the lid, make sure to always place your fingers on the top side of the lid and never in the gap between the lid and the housing of the centrifuge, otherwise you could crush your fingers!

3.5 ROTOR MOUNTING AND DISMOUNTING

Before attaching the rotor on the motor axle, make sure that axle and rotor are clean and undamaged. Wipe all fixing surfaces (motor axle and rotor cone) with clean, soft cloth. Thus, you will avoid potential damages to the axle and motor.

- Mount the rotor on the motor axle and tighten the rotor nut by turning it clockwise, using the supplied hexagonal rotor key.
- To dismount the rotor, turn the rotor nut counter-clockwise, using the hexagonal rotor key and then remove the rotor.



Do not use the rotors, rotor lids and test tubes, which are mechanically or chemically damaged or with visible corrosion defects!



The rotor and the rotor lid must always be securely fastened. Do not begin with centrifugation before the rotor has been securely fastened!

3.6 ROTOR LOADING

Test tubes in the rotor must always be loaded symmetrically. You may use only approved test tubes. Weight difference of the samples in test tubes should be as low as possible in order to avoid potential damages of the motor and to minimize running noise and vibration. Following are examples of correctly and wrongly loaded rotors:

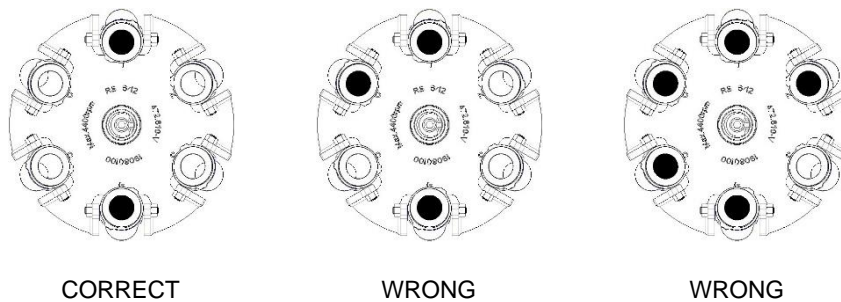
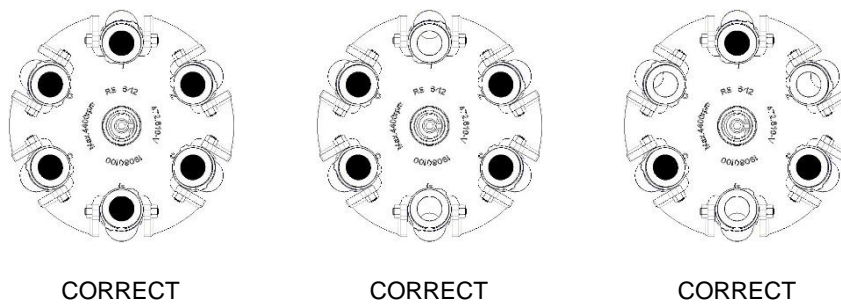
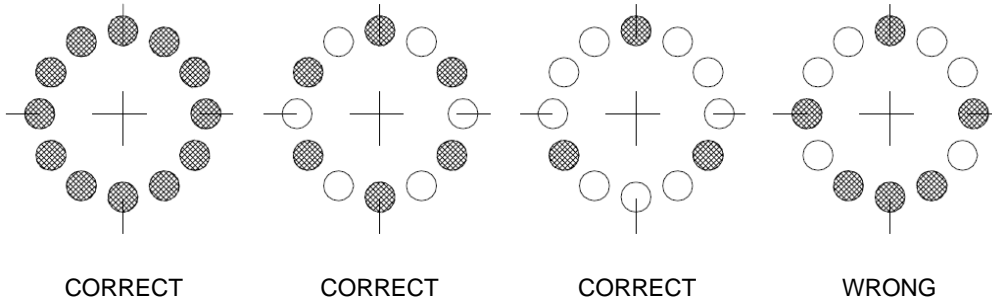

NOTE:

The centrifuge is equipped with imbalance sensor, to ensure safety. Imbalance at high speed may cause test tube breakage, leak or rotor crash. Therefore, additional care should be taken depending on the samples loaded.



In case of rotor imbalance during operation, the centrifuge will automatically stop, and the display will show error message IMBAL OUR.

3.7 COOLING SETTING (Only for CENTRIC 260 R)



The temperature can be set from -19 °C to 40 °C, in steps of 1 °C. If the difference between actual and set temperature is more than ±3 °C, the temperature display will flash.

| | |
|---|---|
|  | <p>By pressing the TEMPERATURE key, you can set the temperature. The key lights up and the current set temperature is displayed.</p> <p>Set new temperature by rotating the knob and confirm it by pressing on the knob. The key light turns off and the actual temperature is displayed.</p> |
|---|---|

NOTE:



To achieve very low temperatures, it is necessary to appropriately reduce the rotational speed of the rotor (e.g.: If you set the temperature to -19 °C, you may not be able to use the max. speed of 18000 RPM, if you want the centrifuge to reach this very low temperature).

3.8 SETTING THE ROTATIONAL SPEED AND CENTRIFUGAL FORCE

| | |
|---|---|
| <p>By pressing the SPEED key, you can set the rotational speed (RPM) and centrifugal force (RCF). The key lights up. By repeated pressings on this key, you select which parameter will be set. When indicator RPM is lit, you can set the rotational speed, and when indicator RCF is lit, you can set the centrifugal force. Set new values of both parameters by rotating the knob and confirm them by pressing on the knob. The key light will then turn off.</p> | |
|  | <ul style="list-style-type: none"> • Rotational speed (indicator RPM is lit) Rotational speed can be set from 200 to 18000 RPM in steps of 10 RPM. The maximum rotational speed is automatically set according to the rotor type in use. |
|  | <ul style="list-style-type: none"> • Relative Centrifugal Force (indicator RCF is lit) Relative centrifugal force can be set from 5 to 31150 x g in steps of 10 x g. Relative centrifugal force is calculated regarding to the radius of used rotor, so the minimum and maximum forces are dependent on the rotor type. |

3.9 SETTING RUN TIME, ACCELERATION AND BRAKING LEVEL

By pressing the TIME key, you can set the time (TIME), acceleration level (▲) and braking level (▼). The key lights up. By repeated pressings on this key, you select which parameter will be set. When indicator TIME is lit, you can set the run time, when indicator ▲ is lit, you can set the acceleration level, and when indicator ▼ is lit, you can set the braking level. Set new values of all parameters by rotating the knob and confirm them by pressing on the knob. The key light will then turn off.

| | |
|---|---|
|  | <ul style="list-style-type: none"> • Run time Run time can be set between 0.10 and 99.5 minutes. Time setting from 0.10 to 9.59 minutes is possible in 1 second steps. Between 10.0 and 99.5 minutes the setting is possible in 10 second steps. By rotating the knob either clockwise until after 99.5 is displayed, or counter-clockwise until after 0.10 is displayed, you can set continuous operation (HLd on display). NOTE: 0.10 = 10 s, 9.59 = 9 min 59 s, 10.0 = 10 min, 99.5 = 99 min 50 s |
|  | <ul style="list-style-type: none"> • Acceleration level (AcX) Acceleration level can be set from 0 to 9. Level 0 means very slow acceleration, level 9 very fast acceleration. |
|  | <ul style="list-style-type: none"> • Braking level (brX) Braking level can be set from 0 to 9. Level 0 means stopping without braking, level 9 maximum braking. |

NOTE:

All the operation parameters can be changed during the operation of the centrifuge, and it starts to work with the new settings after that.

Changing of run time during the operation:

You should be aware, that when you extend run time, the difference between newly set and originally set time is added to current time, and when you shorten run time, the difference is subtracted.

Example: The centrifuge started with time set to 10 minutes. It has been running for 3 minutes. Then you changed the time to 5 minutes. The centrifuge will run for another 2 minutes.

3.10 PROGRAM SETTING



| | |
|--|---|
|  | <p>You can save 100 programs, with different operational parameters, in the centrifuge memory.</p> <p>NOTE: You can cancel the procedure for program setting by pressing the STOP key and return to stand-by mode without confirming the data.</p> |
| <p><u>If you want to use the existing program, follow the next procedure:</u></p> <p>By pressing the PROGRAM key, you can set and select programs. The key lights up. Select new program by rotating the knob and confirm it by pressing on the knob. The key light turns off. Operation parameters set in selected program are displayed on display.</p> | |
| <p><u>If you want to change the existing program, follow the next procedure:</u></p> <p>By pressing the PROGRAM key, you can set the programs. The key lights up. Select the program that you want to change, by rotating the knob. While the PROGRAM key is lit, set the values of individual operation parameters (temperature (only on CENTRIC 260 R), rotational speed, centrifugal force, run time, acceleration level and braking level) using the procedures, described in the previous chapters. If you want to change another program, select it by rotating the knob, and set the values of individual operation parameters for this program. Otherwise skip this step. By rotating the knob, select a program that you want to use and confirm it by pressing on the knob. The light for the PROGRAM key will then turn off. Operation parameters set in selected program are displayed on display.</p> | |

The following table shows factory preset values of operation parameters for all 100 programs:

| Program | Temperature (°C) <small>(Only on CENTRIC 260 R)</small> | Rotational speed (RPM) | Run time (min) | Acceleration level (AcX) | Braking level (brX) |
|---------|---|------------------------------|-------------------|--------------------------------|------------------------|
| 0 | 4 | 13000 | 10 | 6 | 6 |
| 1 | 4 | 10000 | 2 | 9 | 9 |
| 2 | 4 | 1500 | 10 | 6 | 6 |
| 3 | 4 | 3000 | 10 | 9 | 9 |
| 4 | 10 | 4000 | 3 | 6 | 6 |
| 5 | 20 | 15000 | 3 | 9 | 9 |
| 6 | 4 | 4000 | 3 | 6 | 6 |
| 7 | 20 | 8000 | 5 | 9 | 9 |
| 8 | 20 | 5000 | 10 | 6 | 6 |
| 9 | 4 | 16000 | 10 | 9 | 9 |
| 10 | 25 | 1200 | 10 | 5 | 5 |
| 11 | 20 | 3000 | 5 | 5 | 5 |
| ⋮ | 20 | 3000 | 5 | 5 | 5 |
| 99 | 20 | 3000 | 5 | 5 | 5 |

3.11 STARTING AND STOPPING THE CENTRIFUGE

Before starting the centrifuge, turn on the main switch, open the centrifuge lid, insert the rotor and load it with test tubes, close the centrifuge lid and set the operation parameters or select a suitable program.

| | |
|---|---|
|  | <p>By pressing the START key, you start the run of the centrifuge. The key lights up and thus indicates that the centrifuge is running. After the expiration of set running time or after manual stopping of the centrifuge, the braking procedure of the rotor is activated and the centrifuge stops. The next run is possible, when the rotor stops completely.</p> |
|  | <p>By pressing the STOP key, you stop the run of the centrifuge. The key lights up and thus indicates that the centrifuge is stopping. The braking procedure of the rotor is activated and the centrifuge stops. Until the centrifuge stops completely, START key is lit, thus indicating that the rotor is still turning.</p> |



Do not move or knock the centrifuge during operation!



3.12 ROTOR RECOGNITION

Rotor recognition is executed automatically, every time when the centrifuge starts. After rotor change, the centrifuge stops and display shows ROTOR CHG. Press the STOP key to clear this message. New maximum rotational speed is automatically set, to correspond with the inserted rotor. To start the centrifuge again, press the START key.

3.13 DISPLAY OF THE SET VALUES DURING THE RUN

During the run, the centrifuge shows the current values of the operation parameters on displays. If you wish to check the set values of the parameters, select the desired parameter by pressing the corresponding key. The key lights up. Display shows the set value of the parameter. To exit the display of the set values, press on the knob. The key light will then turn off.

3.14 FAST SPIN

| | |
|---|--|
|  <p>(On CENTRIC 260)</p>  <p>(On CENTRIC 260 R)</p> | <p>By pressing and holding the FAST SPIN key (on CENTRIC 260) or START key (on CENTRIC 260 R), you perform the fast spin. The centrifuge will run as long as you hold the key pressed. Time of run in seconds is displayed on time display, and the program display shows FS (fast spin). The acceleration and braking levels are fixed to 9 (the highest), and they can't be changed. When you release the key, the braking procedure of the rotor is activated and the centrifuge stops.</p> |
|---|--|

3.15 FAST COOL FUNCTION (Only for CENTRIC 260 R)

| | |
|---|--|
|  | <p>By pressing the FAST COOL key, you turn on the fast cool function. The key lights up. START key lights up also. The program display shows FC (fast cool). Rotor starts to run automatically with 8000 RPM. Fast cool function cools down the centrifugal chamber to the set temperature. When the temperature is reached, display for rotational speed shows message READY, and the light for the FAST COOL key turns off. Rotor keeps on running and START key is still lit, until you stop the centrifuge by pressing the STOP key. If you don't stop the centrifuge manually, fast cool function turns off automatically after 1 hour.</p> |
|---|--|

NOTE:

If maximum speed of inserted rotor is lower than 8000 RPM, the rotor will be running with the maximum allowed speed for that rotor.

3.16 RESET OF LID LATCH

| | |
|--|---|
|  | <p>By pressing and holding the LID key, you set the lid latch to initial position. This is needed in the case of power failure during the opening of the lid, when lid latch motor stops in undefined position. When power returns, it could happen that you can't open or close the lid. If this happens, press the key for approximately five seconds, until you hear the sound of lid latch motor, then release it. After that, you will be able to open and close the lid normally.</p> |
|--|---|

3.17 AUXILIARY LID RELEASE

In case of power failure, the lid can be opened manually. If power failure occurs during the operation of the centrifuge, the rotor may continue rotating for several minutes, before it stops.



Before auxiliary lid release, turn off the main switch of the centrifuge and wait until rotor fully stops. Check this by looking through the lid window. Otherwise, injury from rotating rotor may occur!

On the bottom side of the centrifuge, by the front left foot, there is a plastic plug, which you pull out of the hole. There is a string fastened to the plug. Pull the string vertically downwards to open the lid of the centrifuge. Then insert the string and the plug back in the hole.

3.18 AUTOMATIC BRAKING AFTER POWER RESTORATION

If power failure occurs during the operation of the centrifuge, the rotor may continue rotating for several minutes, before it stops. When power returns, the centrifuge checks if the rotor is still rotating. If it is still rotating, then the display shows message Error brX (X is a number from 0 to 9 and represents the set braking level). The centrifuge begins with the automatic rotor braking, which is performed with preset braking level. When rotor stops, display shows error message MAINS INT and thus warns you, that power failure occurred during operation and the centrifugation was interrupted. By pressing the STOP key, you exit from error display and go back to stand-by mode. You can use the centrifuge again.

3.19 TEMPERATURE CORRECTION (Only for CENTRIC 260 R)

If you notice a difference between preset temperature on display and actual measured temperature, the centrifuge has temperature correction functionality. Temperature correction is performed by entering the temperature difference in the service parameters of the centrifuge.

Temperature correction may only be performed by an authorized service technician!

Measured temperature depends on a number of factors, like environment temperature, rotational speed, run time, etc.

4. MAINTENANCE AND CLEANING OF THE CENTRIFUGE

4.1 REGULAR SERVICE

We recommend having the centrifuge and associated rotors checked by authorized service at least once a year. You must thoroughly clean and disinfect the centrifuge prior to service.

4.2 CLEANING THE CENTRIFUGE

After every centrifugation, please remove any condensed water from the rotor chamber using a soft, absorbent cloth. After use, leave the centrifuge lid open, so the inside can dry out.

For regular cleaning of the outside surface of the centrifuge and the rotor chamber, use mild neutral detergent. Make sure that no liquid penetrates the inside of the housing.

Open the lid of the centrifuge and turn off the main switch. Disconnect the power cord from mains socket. Remove the rotor with rotor key. Clean all accessible surfaces of the device and accessories at least once a week and every time, when contaminated.

After cleaning with detergent, the rubber seal around the rotor chamber should be thoroughly cleaned with water and lubricated with glycerine, to prevent it from becoming brittle.

For cleaning and disinfection, use only neutral cleaners and disinfectants. Before cleaning or decontaminating the centrifuge, using means and methods not recommended in this manual, you should consult with the manufacturer, in order to avoid the damage to the centrifuge.

To ensure safe and long operation of the centrifuge, please avoid the use of aggressive chemicals, which can damage the centrifuge, rotor and accessories. Please check them regularly for damage caused by corrosion.

4.3 CLEANING THE ROTOR

The rotor and accessories must be regularly cleaned to prevent contamination and corrosion caused by residue. Check the rotor and accessories monthly. This applies in particular to the rotor bores. For cleaning the rotor use a neutral cleaning liquid. This will protect the rotor and extend its service life.



Do not use damaged rotors and accessories for centrifugation!

To avoid the damage to the rotor, replace the sealing rings regularly.

4.4 ROTOR STERILIZATION

The rotors are autoclavable at the temperature of 121°C, for 20 minutes. After the rotor has been autoclaved for a maximum of twenty times, seals of the rotor must be replaced (this is valid for rotors with seals).

5. TROUBLESHOOTING

Review the information below to troubleshoot the operating problems.

5.1 ERROR MESSAGES

If an error occurs during the operation of the centrifuge, an error message appears on the display, and the centrifuge stops automatically. The temperature display (only on CENTRIC 260 R) and the program display show message Er, while speed display and time display show the error message. For the list of errors, see below table.

| DISPLAY | | PROBLEM | SOLUTION | WHO REPAIRS |
|----------------------------------|------|--|--|--------------------|
| SPEED | TIME | | | |
| ROTOR | CHG | Rotor change | Repeat run | User |
| | HI | Rotor speed too high | Reduce speed Check rotor sensor | User Service-SP |
| IMBAL | SEN | Imbalance sensor | Check imbalance sensor | Service-SP |
| | | | Check imbalance sensor | Service |
| | | | Electronics error | Service |
| | OUR | Imbalance to high | Check rotor loading arrangement | User |
| | | | Check the samples weight in the rotor | User |
| | | | Check if the rotor and rotor lid are fastened | User |
| | | | Check the rotor and the lid | User |
| | | | Check rotor sensor | Service-SP |
| | | Repeat the balancing procedure | Service | |
| LID | OPN | The lid of the centrifuge open | Close the lid of the centrifuge | User |
| | SEN | Lid latch not engaged | Open and close the lid of the centrifuge again | User |
| Check lid sensors | | | Service-SP | |
| MOTOR | SEN | Speed sensor error | Check speed sensor | Service-SP |
| | | | Check speed sensor | Service |
| | | | Electronics error | Service |
| | SPD | Speed deviates for more than ± 500 RPM / 5 s | Check rotor, motor and frequency regulator | Service |
| | | | Electronics error | Service |
| T CHA (Only on CENTRIC 260 R) | SEN | Chamber temperature sensor error | Check chamber temperature sensor | Service-SP |
| | | | Check chamber temperature sensor | Service |
| | | | Electronics error | Service |
| | OUR | Chamber temperature over 50 °C | Check refrigerating system | Service |

| DISPLAY | | PROBLEM | SOLUTION | WHO REPAIRS |
|---|------------|--|---|-------------|
| SPEED | TIME | | | |
| T CON (Only on CENTRIC 260 R) | SEN | Condenser temperature sensor error | Check condenser temperature sensor | Service-SP |
| | | | Check condenser temperature sensor | Service |
| | | | Electronics error | Service |
| | OUR | Condenser temperature over 80 °C | Check refrigerating system | Service |
| | | | Check refrigerating parameters | Service-SP |
| T REC (Only on CENTRIC 260 R) | TI | Set temperature not reached in 2 hours | Check the suitability of centrifuge installation and environmental conditions | User |
| | | | Check refrigerating system | Service |
| | | | Check refrigerating parameters | Service-SP |
| DRIVE | HIV | Voltage overload on the DC link | Reduce braking level | User |
| | | | Error on frequency regulator | Service |
| | | | Error on braking resistor | Service |
| | LOV | Voltage too low on the DC link | Check power supply | Service |
| | | | | |
| | OC | Current overload of the motor | Repeat run | User |
| | | | Reduce acceleration level | User |
| | | | Check start-up parameters | Service-SP |
| | | | Check motor | Service |
| | HOT | Driver temperature too high | Error on frequency regulator | Service |
| Reduce speed | | | User | |
| Check motor | | | Service | |
| | | | Error on frequency regulator | Service |
| MAINS | INT | Power failure during the run | Repeat run | User |
| READY (Only on CENTRIC 260 R) | | Fast cool function reached the set temperature | Stop the centrifuge by pressing the STOP key | User |
| ----- | --- | After 1 hour of standstill centrifuge goes to sleep mode (lines on all displays) | Press any key | User |

Note: SP = service parameters

5.2 EXIT FROM ERROR DISPLAY



By pressing the **STOP** key, you exit from error display and go back to stand-by mode.

If error is still displayed, turn off the main switch of the centrifuge and turn it on again.

If the centrifuge still doesn't return to stand-by mode, call service!

5.3 USER'S PARAMETERS

With user's parameters, you can check and set some of the operational properties of the centrifuge.

For entering to user's parameters, the centrifuge must be in stand-by mode. Simultaneously press the SPEED key (on CENTRIC 260) or the TEMPERATURE key (on CENTRIC 260 R) and PROGRAM key and hold them for about 5 seconds. When the first parameter is displayed and the TIME key lights up, release the keys.

You can select the parameters by rotating the knob. If you want to change the setting of the parameter, press the SPEED key, which lights up. The light for the TIME key will then turn off. Then change the setting of the parameter by rotating the knob and confirm it by pressing on the knob. The light for the SPEED key will turn off and the TIME key will light up.

To exit from user's parameters, press the START key.

| DISPLAY | | PARAMETER DESCRIPTION |
|---------|--------------------------------|--|
| SPEED | TIME | |
| dIS | bSE | Block the changing of operation parameters during the operation of the centrifuge. (dIS = disable, Enb = enable) |
| dECrE | tIn | Decreasing or increasing of time display. (dECrE = decreasing, InCrE = increasing) |
| Enb | bEP | Turn on the beeper. (dIS = disable, Enb = enable) |
| 1 | SLE | Time, after which the centrifuge goes to sleep mode and fast cool function turns off (only on CENTRIC 260 R). (0 - 99 hours) |
| Enb | COL (Only on CENTRIC 260 R) | Start of cooling at the closing of the lid. (dIS = disable, Enb = enable) |
| dIS | tSS | Time starts running after the speed is reached, instead at motor start. (dIS = disable, Enb = enable) |
| dIS | tSC (Only on CENTRIC 260 R) | Time starts running after the temperature is reached, instead at motor start. (dIS = disable, Enb = enable) |
| Enb | SAP (Only on CENTRIC 260 R) | Temperature compensation (display of sample temperature instead of chamber temperature). (dIS = disable, Enb = enable) |

Note: Values in SPEED column of the above table are factory default values of user's parameters.

5.4 REPLACING THE CENTRIFUGE FUSES

CENTRIC 260:

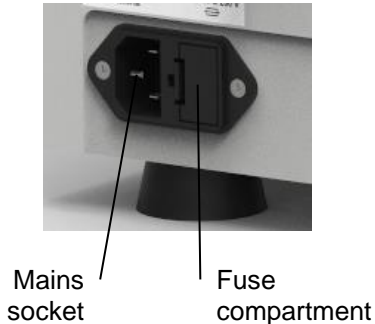

The following fuses are required for CENTRIC 260:
 2 x 6.3AT 250V (230V)
 2 x 10AT 250V (120V)

- Unplug mains plug from the mains socket.
- By pressing the locking device on the left side of the fuse compartment, the fuse holder is released and you can pull it out.
- Replace fuses.
- Insert fuse holder and push it, until it locks.

CENTRIC 260 R:

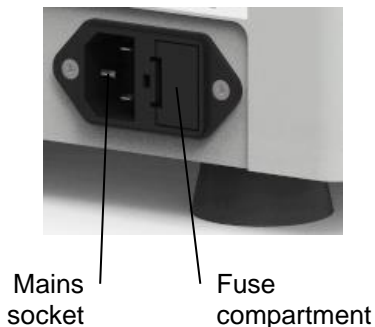

The following fuses are required for CENTRIC 260 R:
 2 x 16AT 250V (230V)
 2 x 16AT 250V (120V)

- Unplug mains plug from the mains socket.
- By pressing the locking device on the left side of the fuse compartment, the fuse holder is released and you can pull it out.
- Replace fuses.
- Insert fuse holder and push it, until it locks.

6. TECHNICAL DATA

CENTRIC 260:

| | |
|---|--|
| Code: | 472.3.450 - 230 V 1472.3.450 - 120 V |
| Power supply: | 230 V ± 10 %, 50 / 60 Hz 120 V ± 10 %, 50 / 60 Hz |
| Power consumption: | 450 W |
| Fuses: | 230 V = 2 x 6.3 A T 120 V = 2 x 10 A T |
| Protection class: | I |
| Rotational speed: | 200 to 18000 RPM |
| Maximum centrifugal force: | 31150 x g |
| Maximum load: | 6 x 50 ml |
| Maximum kinetic energy: | 7300 Nm |
| Max. density of material to be centrifuged: | 1.2 g/ml |
| Noise level at max. speed: | ≤ 62 dB(A) |

| | |
|----------------------------|---|
| Run time: | 10 s to 99 min 50 s, continuous operation (HOLD) |
| Number of programs: | 100 programs |
| Acceleration: | levels from 0 to 9 |
| Deceleration: | levels from 0 to 9 (0 - no braking) |
| Ambient temperature: | 2 °C to 35 °C |
| Maximum relative humidity: | 75 %, non-condensing |
| Dimensions (W x D x H): | 360 x 430 x 288 mm |
| Weight: | 22.5 kg |

CENTRIC 260 R:

| | |
|---|--|
| Code: | 472.3.500 - 230 V 1472.3.500 - 120 V |
| Power supply: | 230 V ± 10 %, 50 / 60 Hz 120 V ± 10 %, 50 / 60 Hz |
| Power consumption: | Centrifuge: 700 W Compressor: 350 W |
| Fuses: | 230 V = 2 x 16 A T 120 V = 2 x 16 A T |
| Protection class: | I |
| Rotational speed: | 200 to 18000 RPM |
| Maximum centrifugal force: | 31150 x g |
| Maximum load: | 6 x 50 ml |
| Maximum kinetic energy: | 7300 Nm |
| Max. density of material to be centrifuged: | 1.2 g/ml |
| Noise level at max. speed: | ≤ 60 dB(A) |
| Run time: | 10 s to 99 min 50 s, continuous operation (HOLD) |
| Number of programs: | 100 programs |
| Acceleration: | levels from 0 to 9 |
| Deceleration: | levels from 0 to 9 (0 - no braking) |
| Temperature of centrifugation: | - 19 °C to 40 °C |
| Fast cool function (FC): | from 20 °C to 4 °C in approx. 5 minutes |
| Ambient temperature: | 2 °C to 35 °C |
| Maximum relative humidity: | 75 %, non-condensing |
| Dimensions (W x D x H): | 360 x 675 x 288 mm |
| Weight: | 50 kg |

We reserve the right to alter specification details without prior notice or liability!

7. APPENDIX

7.1 CALCULATION OF CENTRIFUGAL FORCE

For the calculation of the centrifugal force (RCF), stated as a multiple of the gravitational force "g", use the following formula:

$$RCF = 11.18 \times r \times (n / 1000)^2$$

RCF Relative centrifugal force (x g)
 r Radius of the rotor (cm)
 n Rotational speed (RPM)

7.2 CALCULATION OF MAXIMUM PERMITTED ROTOR SPEED

Users are responsible and must consider the limitations for maximum permitted rotor speed and about correct rotor load.

The maximum permitted speed for each type of rotor is marked on each rotor. It is defined for the use of samples with maximum density of 1.2 g/cm³.

If you need to use higher density samples, maximum permitted rotor speed must be reduced according to the following formula:

$$M = (1.2 \times n^2 / S)^{1/2}$$

M Reduced maximum permitted rotor speed
 n Maximum permitted rotor speed for samples with density of 1.2 g/cm³
 S Density of used sample

7.3 EQUIPMENT DECONTAMINATION



The device may be contaminated.

If infectious materials get into the centrifugal chamber, on the rotors or accessories, they must be appropriately decontaminated.

They may only be decontaminated by hand with soft cloth and liquids, which contain the following ingredients: ethanol, n-propanol, ethyl hexanol.

After using disinfectants, remove the disinfectant residue by wiping it with a damp cloth.

The surfaces must be dried immediately after disinfecting.

You must perform the decontamination before the device is shipped to the service and before it is sent to disassembly after the end of the life cycle.

7.4 TRANSPORT AND STORAGE

Transport and storage are allowed only in the original packaging. Remove the rotor from the centrifuge before transport and storage.

The centrifuge is heavy. To prevent possible injuries, at least two people should lift and carry the centrifuge by holding it at the bottom from opposite sides. Use a transport aid for transferring the device.

Permissible environmental conditions for transport and storage of the equipment:

- Ambient temperature: - 25 °C to 60 °C
- Relative humidity: 10 % to 75 %

7.5 EQUIPMENT DISPOSAL



This equipment is marked with the crossed-out wheeled bin symbol, to indicate that this equipment may not be disposed of as unsorted municipal waste.

It's your responsibility to correctly dispose of your equipment at life-cycle end, by handing it over to an authorized facility for separate collection and recycling of waste equipment. It's also your responsibility to decontaminate your equipment in case of biological, chemical or radiological contamination, and so protect the persons involved in the disposal and recycling of the equipment from health hazards.

For more information about where you can dispose of your waste equipment, please contact your local dealer, from whom you purchased the equipment.

By doing so, you will help to preserve natural and environmental resources and you will ensure that your equipment is recycled in a manner that protects human health.



EU DECLARATION OF CONFORMITY

Manufacturer / name and address

Domel, d.o.o.
BU Laboratory Systems
Otoki 21
4228 Železniki
Slovenia

DOMEL®

We declare under our sole responsibility that

product:
type / model:

Laboratory centrifuge
Centric 260 / R

is in conformity with the provisions of the following regulations and also complies with the following standards

1. Directive 2014/35/EU of the European Parliament and of the Council of 26 February 2014 on the harmonisation of the laws of the Member States relating to the making available on the market of electrical equipment designed for use within certain voltage limits

Standards: EN 61010-1:2010, EN 61010-2-020:2017

2. Directive 2014/30/EU of the European Parliament and of the Council of 26 February 2014 on the harmonisation of the laws of the Member States relating to electromagnetic compatibility

Standards: EN 61326-1:2013

3. Directive 2011/65/EU of the European Parliament and of the Council of 8 June 2011 on the restriction of the use of certain hazardous substances in electrical and electronic equipment, amended by Commission Delegated Directive (EU) 2015/863 and Directive (EU) 2017/2102 of the European Parliament and of the Council

Standards: EN IEC 63000:2018

Place and date of issue

Name, surname and signature of authorized person

Železniki, 19.08.2020

manager

Andrej Eržen